



# Alpha VL $\alpha^{VL}$

Medium Voltage Vacuum  
Circuit Breaker  
Product Catalog





# Leading The Future of Electrification

- A Global Heritage Brand with 130 Years of Product Innovation
- Perfect Products, Creative Services, and Competitive Price

## Since 1886, Westinghouse Has Brought The Best To Life.

Westinghouse remains a trusted name globally in consumer and industrial products. Built on a heritage of innovation and entrepreneurial spirit, Westinghouse products were the first to supply the United States with AC electric power, transmit a commercial radio broadcast and capture man's first step on the moon. Today, Westinghouse continues to grow its diverse portfolio with a wide range of product categories that include home appliances, consumer electronics, lighting and power generation.





# Worldwide

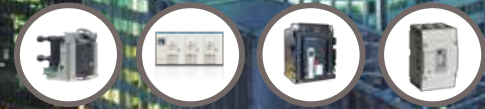

## OUR PROMISE

Westinghouse is built upon a tradition of dependability and innovation.

Today, we strive to make everyday life a little better by offering a wide range of quality products and services you can trust.



## WHY WESTINGHOUSE ?

Since 1886, Westinghouse has brought the best to life. Today, Westinghouse Electric Corporation remains a trusted name globally in consumer and industrial products. Built on a heritage of innovation and entrepreneurial spirit. Today, Westinghouse continues to grow its diverse portfolio, which includes a wide range of product categories, including home appliances, consumer electronics, lighting and power generation.



# CONTENT

<b>Product Profile</b> .....	<b>05</b>
<b>Product Feature</b> .....	<b>07</b>
<b>Technical Parameter</b> .....	<b>11</b>
<b>Installation Dimension</b> .....	<b>13</b>
<b>Electrical Connection Diagram</b> .....	<b>18</b>

## Alpha VL Medium Voltage Vacuum Circuit Breaker

# PRODUCT FEATURE



Alpha VL

As the earliest leader to the research and development, series production and sales of arc extinguish chamber, Westinghouse has been the pioneer in this field, committed to push the appliance of vacuum arc extinguishing technology among the use from low to high voltage products, and provides the safest, the most reliable, environment-friendly PTD products for our customers.

Alpha VL medium voltage VCB is the perfect mix of the reliable R&D and manufacturing technology of Westinghouse vacuum arcing chamber, as well as advanced operation structure.

Alpha VL medium voltage VCB fully complies with DL, IEC and VDE standards and is widely used in the protection and control of medium voltage power distribution system in the field of energy, infrastructure, industrial, commercial and civil construction. They are especially applicable to newly-built or renovated medium voltage substations, as well as the switches for various types of loads and frequent operations.

### Product Feature

- Curved patent appearance, adhering to the German exquisite quality; Excellent insulation performance, to ensure the safety of personal and equipment.
- 12~40.5kV, 630~5000A, 25~50kA, Full range coverage, which can be compatibled with mainstream medium voltage cabinet size and interface.
- Excellent environmental adaptability, withstand -25 degrees ~40 degrees Celsius and 4700 meters above sea level extreme test.
- Patent solid sealing pole, green environmental protection; The chassis of the car is black zinc plating process, salt spray test up to 200 hours.
- Spring mechanism and permanent magnetic mechanism were designed by module, mechanical life up to 60000 times and 100000 times respectively.



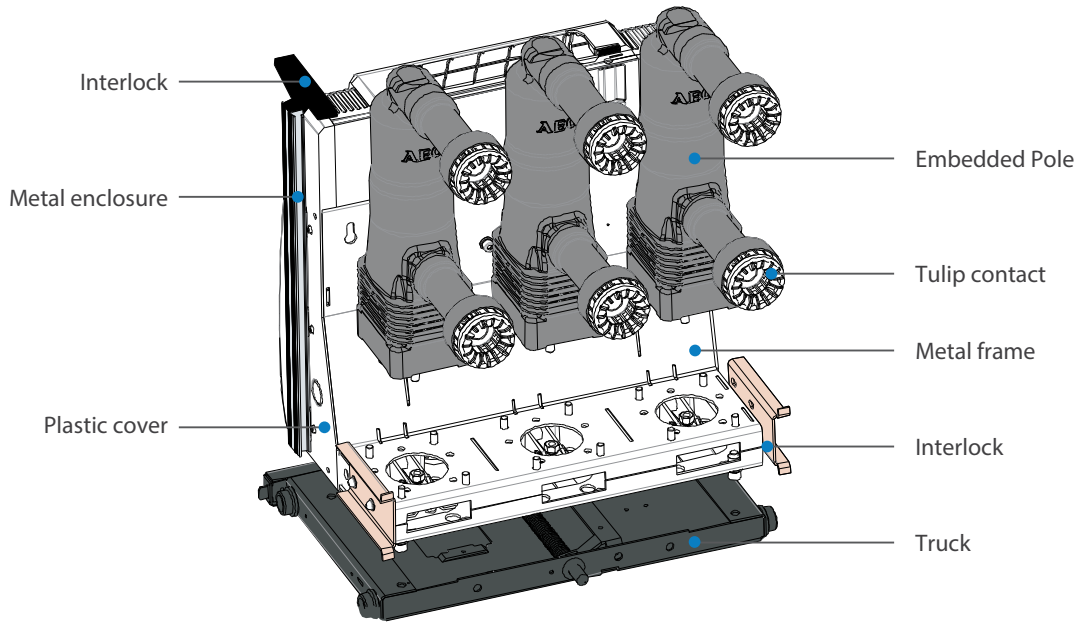

**Product coding**

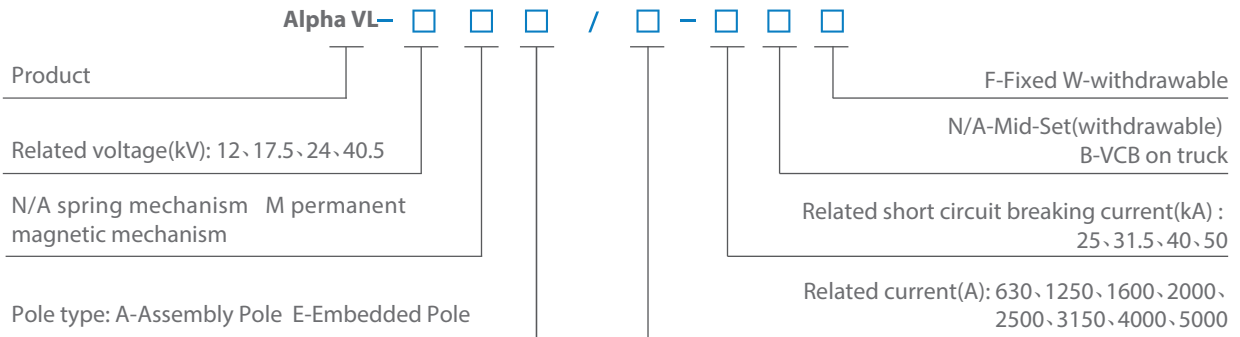

## Alpha VL Medium Voltage Vacuum Circuit Breaker

# PRODUCT FEATURE

### Product Standard

The products fully comply with DL, IEC and VDE standards and are widely used in the protection and control of medium voltage power distribution system in energy, infrastructure, industrial, commercial and civil construction:

- IEC622271-100-2012 «High Voltage AC Circuit Breaker»
- IEC60694-2002 «Common Specification for High Voltage Switchgear and Controlgear Standards»
- DIN VDE 0671 «High-voltage Switchgear and Controlgear»

Alpha VL VCB have passed all kinds of test as below, to make sure the products can work steadily and reliably with correct installation.

- **Type test :**  
Temperature rise test, power-frequency withstand test, lightning impulse withstand test, short time/peak withstand test, mechanical endurance test, short circuit breaking test and cable off-load switching capacity test
- **Special test**  
Insulation test and temperature test under the altitude 4700m  
Capacitor bank breaking test test(800A single capacitor set)
- **Outgoing inspection**  
Mechanical test, power-frequency withstand test, insulation test for control system, resistance test for main loop, mechanical and electrical operation check

### Environmental data

- **The conditions of temperature**
  - The ambient air temperature does not exceed 40 °C
  - The minimum ambient air temperature is -25 °C
  - The average value of ambient air temperature measured over a period of 24 h, does not exceed 35 °C
- **The conditions of earthquake intensity**
  - no more than 8 degree.
- **The conditions of altitude**
  - The altitude does not exceed 1000m
  - We can also offer the product which can exceed 4700m altitude, buyer need to check with the manufacture firstly when placing order
- **The conditions of humidity(25 °C)**
  - the average value of the relative humidity, measured over a period of 24 h, does not exceed 95%
  - the average value of the relative humidity, measured over a period of one month, does not exceed 90%;
  - the average value of the water vapour pressure, over a period of 24 h, does not exceed 2.2 kPa
  - the average value of the water vapour pressure, over a period of one month, does not exceed 1.8 kPa.
- **Others**
  - Storing place should be free from condensation, fire, explosion, chemical corrosion, severe dirty and heavy shakes condition.
  - The ambient air is not significantly polluted by dust, smoke, corrosive and/or flammable gases, vapors or salt. EMI should not exceed 1.6kV in the secondary system.

**Vacuum Arcing Chamber**
**The world's leading technology  
of Westinghouse vacuum arcing chamber**

Westinghouse vacuum arcing chamber is applicable to the medium voltage systems with a rated voltage of 12kV~40.5kV

- Indoor circuit breaker
- Outdoor circuit breaker
- Contact
- Load switch

**Precision Process & High Quality**

- High quality CuCr material for contact
- High performance production and test equipment
- Advance and reliable manufacturing process
- High vacuum performance  $P < 1 \times 10^{-5}$  Pa
- interception current  $< 3A$
- low resistance and temperature rise
- low breakdown field strength
- low air leakage  $< 14ppm$



Alpha VL Medium Voltage Vacuum Circuit Breaker

# PRODUCT FEATURE

## Embedded Pole



### Precision Process & High Quality

Alpha VL medium voltage vacuum circuit breaker use LSR (Liquid silicone rubber) type embedded pole to achieve the high mechanical and electrical performance.

- solid insulation protect vacuum interrupters from damage
- high performance of insulation
- not influenced by environment
- Resist to dust and salt spray without any maintenance

Alpha VL

### A new generation of insulated and embedded poles made of LSR engineering plastic

LSR engineering plastic is a new generation of embedded poles, with high performance and green environment standard.

- high efficient
- low energy consumption
- green and recycle usage material



## Mechanism



Special process on self-lubricated bearing make the mechanism 60000 life cycles without any maintenance.

Special treatment makes the mechanism work reliable under all kinds of severe environment.

### High reliable mechanism

- the lower overtravel of the moving contacts means lower mechanical stress to the bellows of the vacuum interrupter,
- Alpha VL medium voltage vacuum circuit breaker use the new design spring mechanism, which is totally not influenced by operator.
- Modular design makes the minimal impact of mechanism performance from the variance of frame
- The charging spring, motor/manual clutch device,
- The mechanism is developed as simple design and convenient usage, with accessories easily installation, make the mechanism more reliable.

**Alpha VL Medium Voltage Vacuum Circuit Breaker**

# TECHNICAL PARAMETER

**Main Technical Parameter**

Item	Unit	Value			
Rated voltage	kV	12	17.5	24	40.5
Rated current	A	630 1250 1600 2000 2500 3150 4000* 5000*	630 1250 1600 2000 2500 3150 4000*	630 1250 1600 2000 2500 3150*	630 1250 1600 2000 2500 3150*
Rated power frequency withstand voltage(1min)	kV	42	38	65	95
Rated lightning impulse withstand voltage	kV	75	95	125	185
Rated frequency	Hz	50/60	50/60	50/60	50/60
Rated short circuit breaking current	kA	25 31.5 40 50	25 31.5 40	25 31.5	25 31.5 40
Rated short time withstand current(4s)	kA	25 31.5 40 50	25 31.5 40	25 31.5	25 31.5 40
Rated peak withstand current	kA	63 100 125 135	63 80 100	63 80	63 80 100
Rated peak making current	kA	63 80 100 125	63 80 100	63 80	63 80 100
Operation sequence	kA	O-0.3s-CO-180s-CO(lower than 40kA) O-180s-CO-180s-CO(equal or higher than 40kA)	O-0.3s-CO-180s-CO(lower than 40kA) O-180s-CO-180s-CO(equal or higher than 40kA)	O-0.3s-CO-180s-CO	O-0.3s-CO-180s-CO(lower than 40kA) O-180s-CO-180s-CO(equal or higher than 40kA)
Rated single/back to back capacitor bank breaking current	A	800/630/400	630	630	800/630
Breaker grade		E2-M2-C2	E2-M2-C2-S1	E2-M2-C2	E2-M2-C2
Mechanical endurance	Cycles	60000	10000	30000	10000
Short circuit/breaking endurance	Cycles	≤40kA 100 50kA 30	E2 class 274	30	30

\*Air cooled cabinet

### Other Technical Parameter

Item	Unit	Value			
Rated voltage	kV	12	17.5	24	40.5
Closing time(rated voltage)	ms	20~50			
Opening time(rated voltage)	ms	30~70			
Clearance between Contact	mm	9±1	9±1	13±1	18±1
Overtravel	mm	3.5±0.5	3.5±0.5	4±1	4±1
Contact closing tripping time	ms	≤2	≤2	≤2	≤3
Synchronization of 3-phase contact closing and opening	ms	≤2	≤2	≤2	≤3
Average opening speed	m/s	0.9~1.3	0.9~1.3	1.1~1.6	1.3~1.9
Average closing speed	m/s	0.4~0.8	0.4~0.8	0.6~1.0	0.5~1.0
Loop resistance	μΩ	≤50 (630A)	≤45 (1250A)	≤40 (1600~2000A)	≤35 (over 2500A)
Rated operation voltage for mechanism	V	AC:110,220 DC:110,220			
Rated voltage for energy storing motor	V	AC:110,220 DC:110,220			
Energy storing period	S	≤10			

### Mechanism and electromagnetic coils

Rated operation voltage(V)	Energy storing motor(A)	Closing electromagnetic coil(A)	Opening electromagnetic coil(A)	Blocking magnet(mA)
110 DC	0.8A	1.4	1.4	25
220 DC	0.4A	1.3	1.3	25



Alpha VL Medium Voltage Vacuum Circuit Breaker

# INSTALLATION DIMENSION

12kV and 17.5kV Withdrawable Embedded Pole - Pole center distance 150mm

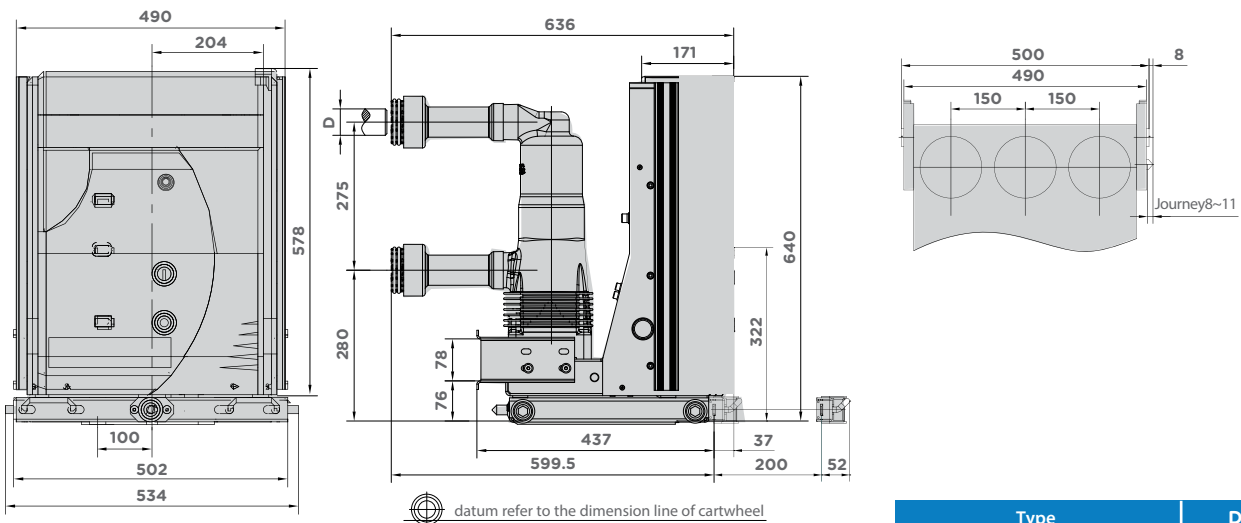

12kV and 17.5kV Withdrawable Embedded Pole - Pole center distance 210mm

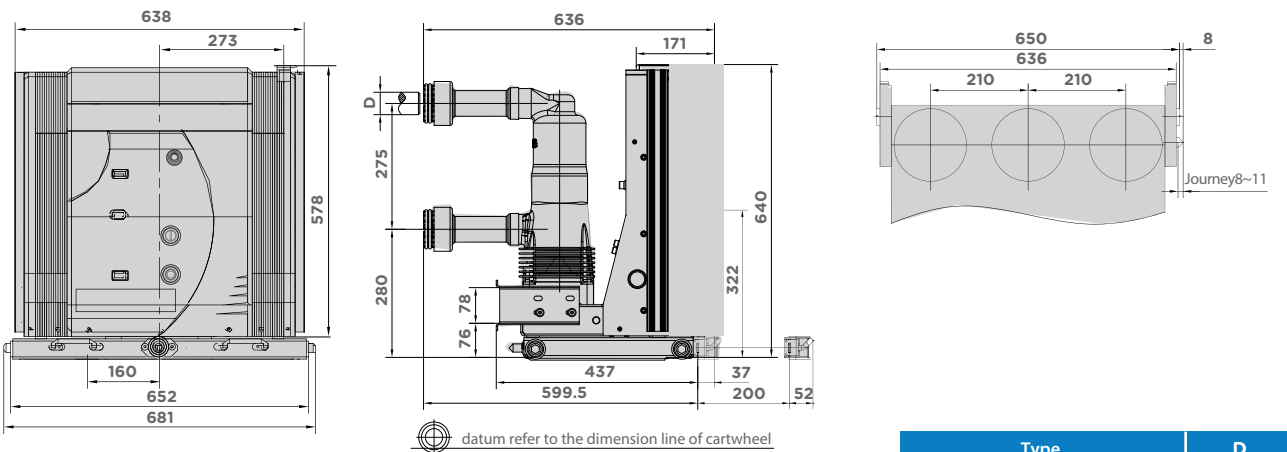

Alpha VL Medium Voltage Vacuum Circuit Breaker

# INSTALLATION DIMENSION

Alpha VL

24kv Withdrawable Embedded Pole

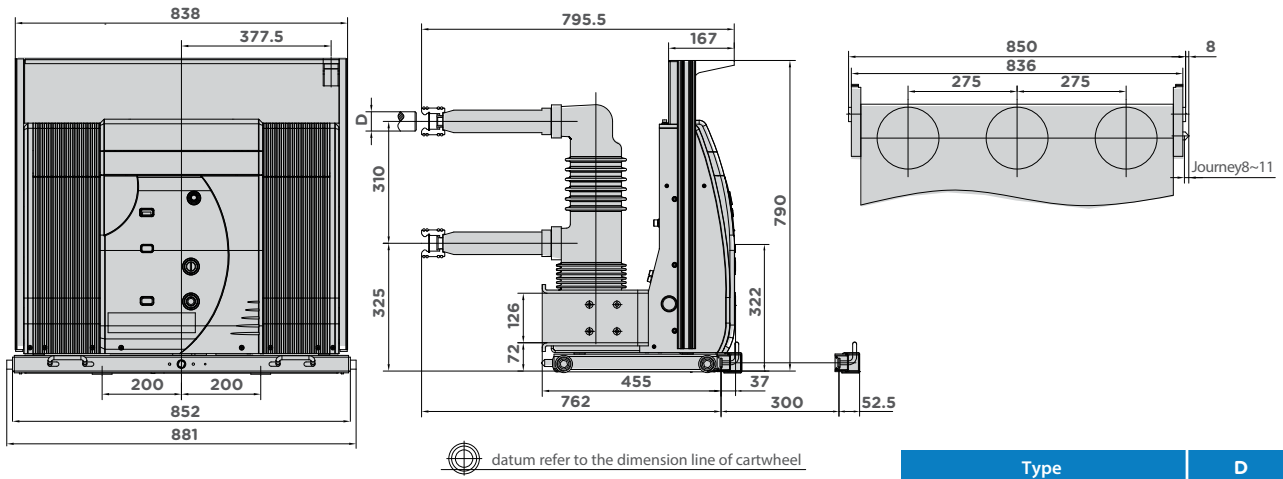

Type	D
630A/25~31.5kA	Ø35
1250A/25~31.5kA	Ø49

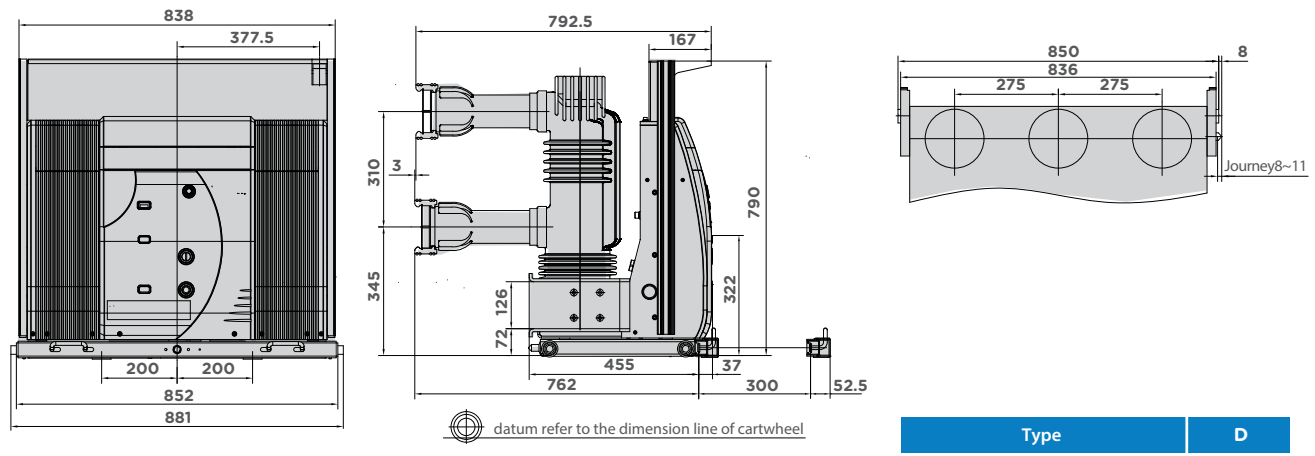

Type	D
1600A/25~31.5kA	Ø55
2000A/25~31.5kA	Ø79
2500A/25~31.5kA	Ø109
3150A/25~31.5kA	Ø109

## 40.5kv Withdrawable Embedded Pole

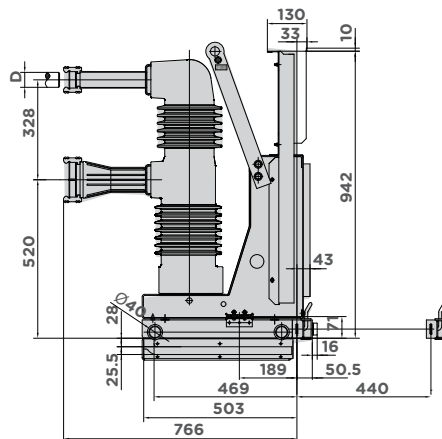
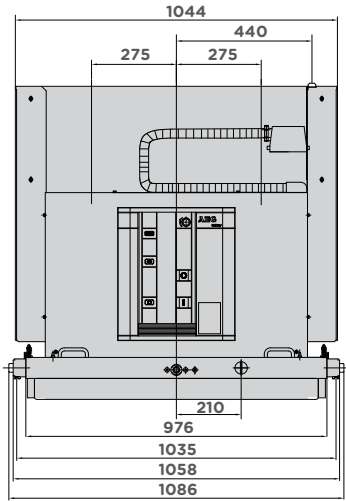

datum refer to the dimension line of cartwheel

Type	D
1250A/25~31.5kA	Ø49
1600A/25~31.5kA	Ø55
2000A/25~31.5kA	Ø79
2500A/25~31.5kA	Ø109

## 40.5kv Fixed Embedded Pole

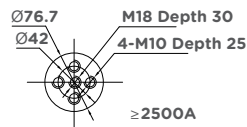
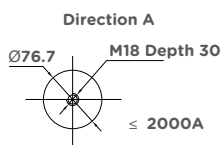
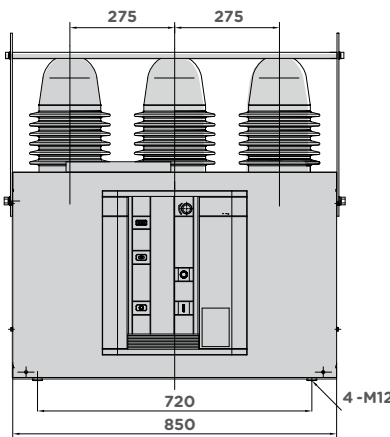
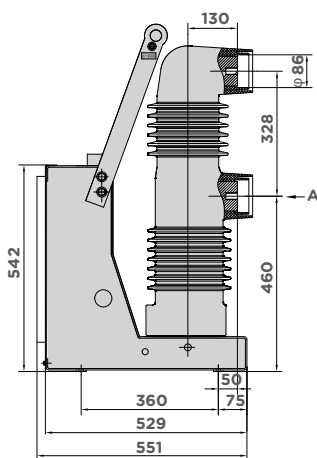

Type
1250A/25~31.5kA
1600A/25~31.5kA
2000A/25~31.5kA
2500A/25~31.5kA





**Withdrawable (58Pin)**

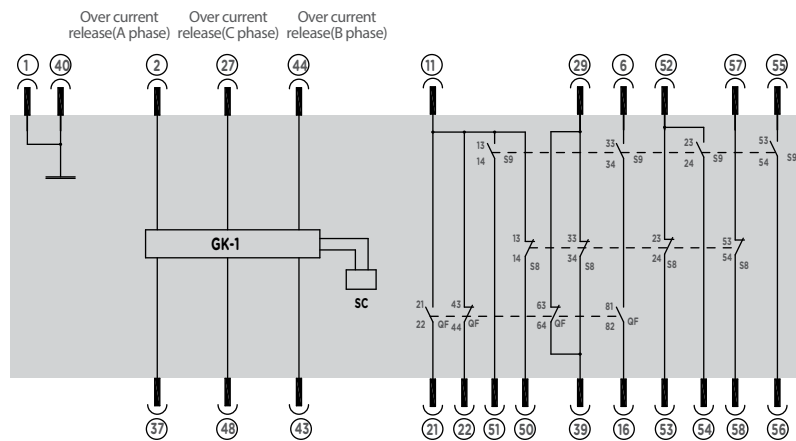
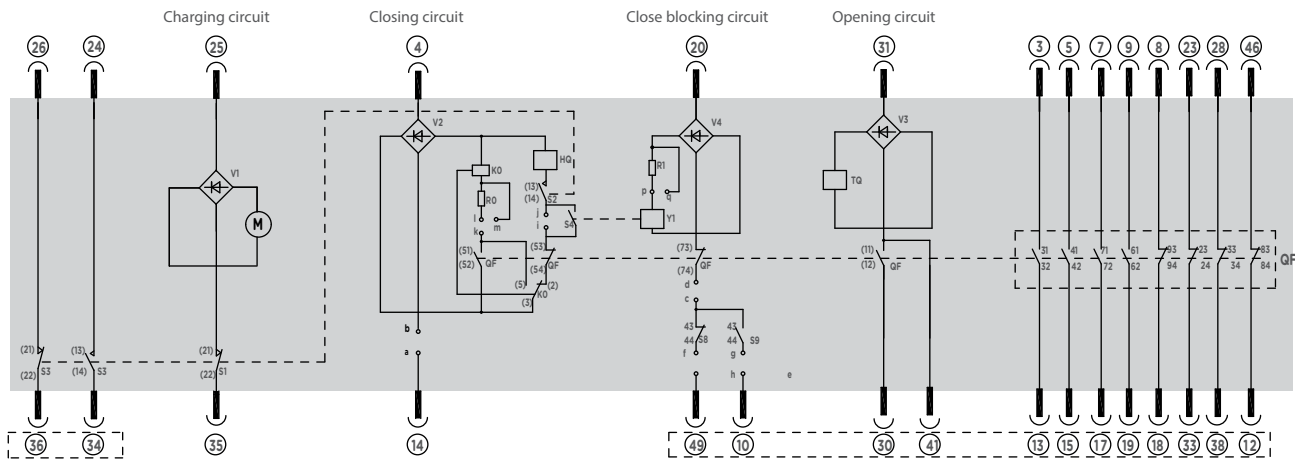

**Instruction:**

1. The status of breaker in the drawings is on the test position, opening and not charged.
2. When using DC as operation power, make sure the polarity is consistency in the dot line area, connect the motor as the diagram.

**Selection of operation:**

Operation power \ Jumper wire	p-q	m-l
AC/DC 220V		/
AC/DC 110V	✓	✓

Remark: the position of optional components: " / " means open; " ✓ " means connection

Status of jumper wire \ Configuration	Jumper wire	Configuration								
		a-b	c-d	e-f	g-h	a-f	a-g	b-c	i-j	l-k
with anti-pumping relay	with closing block function	✓	✓	✓	✓				/	✓/
	without closing block function	/	/	/	/	✓	✓	✓	✓	✓
without anti-pumping relay	with closing block function	✓	✓	✓	✓	/	/	/	/	/
	without closing block function	/	/	/	/	✓	✓	✓	✓	/

S9: Auxiliary switch for service position	HQ: Closing release	GK-1: controller
S8: Auxiliary switch for test position	TQ: Opening release	V1~V4: Rectifier
S4: Auxiliary switch for block magnet	R0~R1: Resistance	K0: Anti-pumping relay(optional)
S1~S3: Microswitch of motor	A~M: terminal of jumper	Y1: Closing block magnet(optional)
QF: Auxiliary switch	M: Charging motor	

# Alpha VL Medium Voltage Vacuum Circuit Breaker

## ELECTRICAL CONNECTION DIAGRAM

Withdrawable (64Pin)

Alpha VL

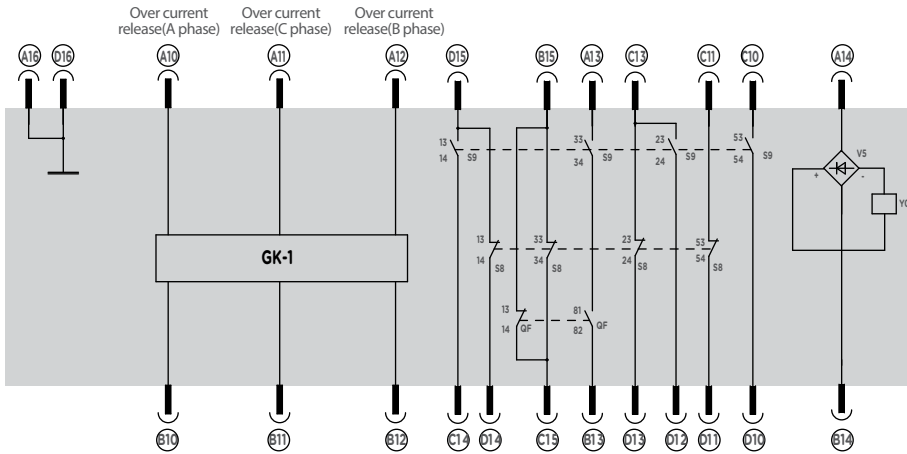
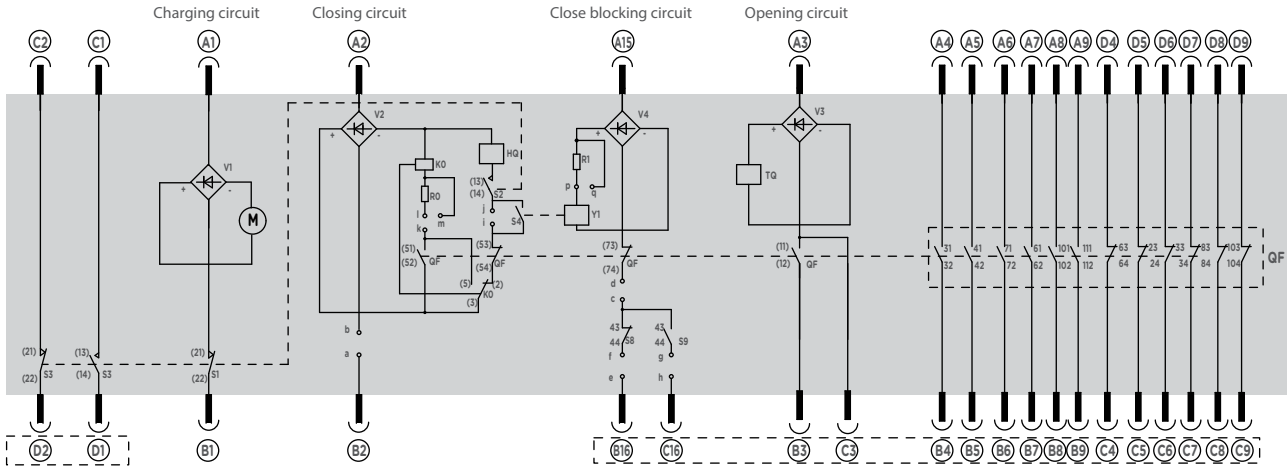

**Instruction:**

- 1.The status of breaker in the drawings is on the test position, opening and not charged.
- 2.When using DC as operation power, make sure the polarity is consistence in the dot line area, connect the motor as the diagram.

**Selection of operation:**

Operation power	Jumper wire	
	p-q	m-l
AC/DC 220V		/
AC/DC 110V	✓	✓

Remark: the position of optional components:“/” means open; “√” means connection

Status of jumper wire	Jumper wire								
	a-b	c-d	e-f	g-h	a-f	a-g	b-c	i-j	l-k
Configuration									
with anti-pumping relay	✓	✓	✓	✓				/	✓
without anti-pumping relay	✓	✓	✓	✓	/	/	/	/	/

S9:Auxiliary switch for service position	HQ:Closing release	GK-1:controller
S8:Auxiliary switch for test position	TQ:Opening release	V1~V5:Rectifier
S4:Auxiliary switch for block magnet	R0~R1:Resistance	K0:Anti-pumping relay(optional)
S1~S3: Microswitch of motor	A~M:terminal of jumper	Y0:Interlock of truck(optional)
QF: Auxiliary switch	M: Charging motor	Y1:Closing block magnet(optional)

## Fixed (amphenol connector)

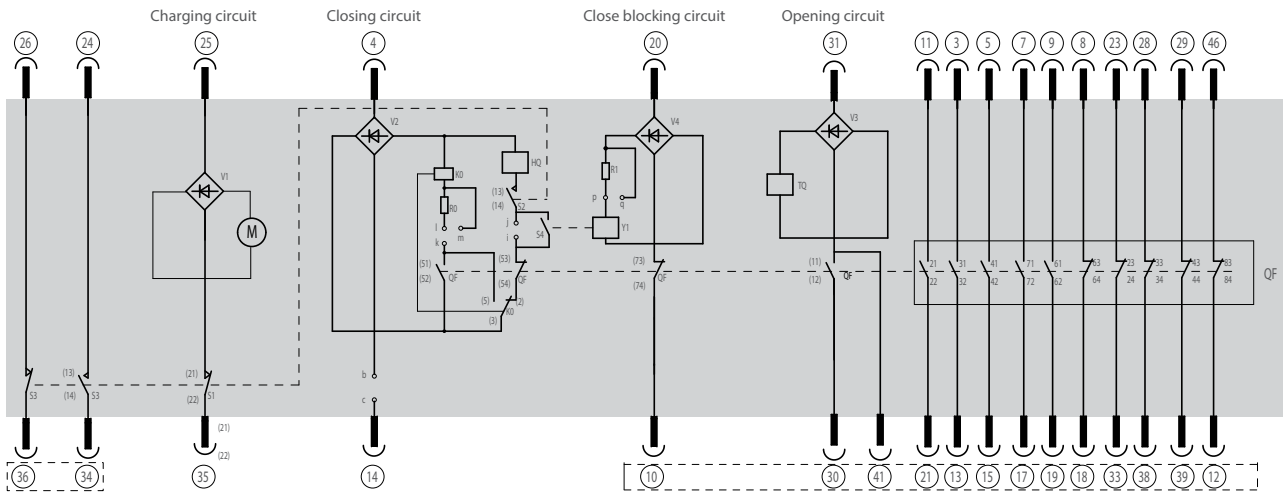

## Closing release

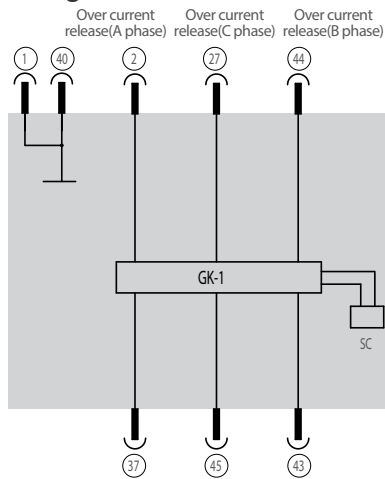

## Selection of operation:

Operation power	Jumper wire	
	p-q	m-l
AC/DC 220V	/	/
AC/DC 110V	✓	✓

Remark: "/" means open; "✓" means connection

## Instruction:

When using DC as operation power, make sure the polarity is consistency in the dot line area, connect the motor as the diagram.

## the position of optional components:

Configuration	Status of jumper wire	Jumper wire		
		b-c	i-j	l-k
with anti-pumping relay	with closing block function	✓	/	✓
	without closing block function	✓	✓	✓
without anti-pumping relay	with closing block function	✓	/	/
	without closing block function	✓	✓	/

S4:Auxiliary switch for block magnet	M: Charging motor	GK-1:controller
QF:Auxiliary switch	SC:Over current release(optional)	V1~V4:Rectifier
S1 ~ S3:Microswitch of motor	Y1:Closing block magnet(optional)	K0:Anti-pumping relay(optional)
HQ:Closing release		
TQ:Opening release		

VCB on truck (64Pin)

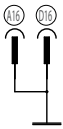
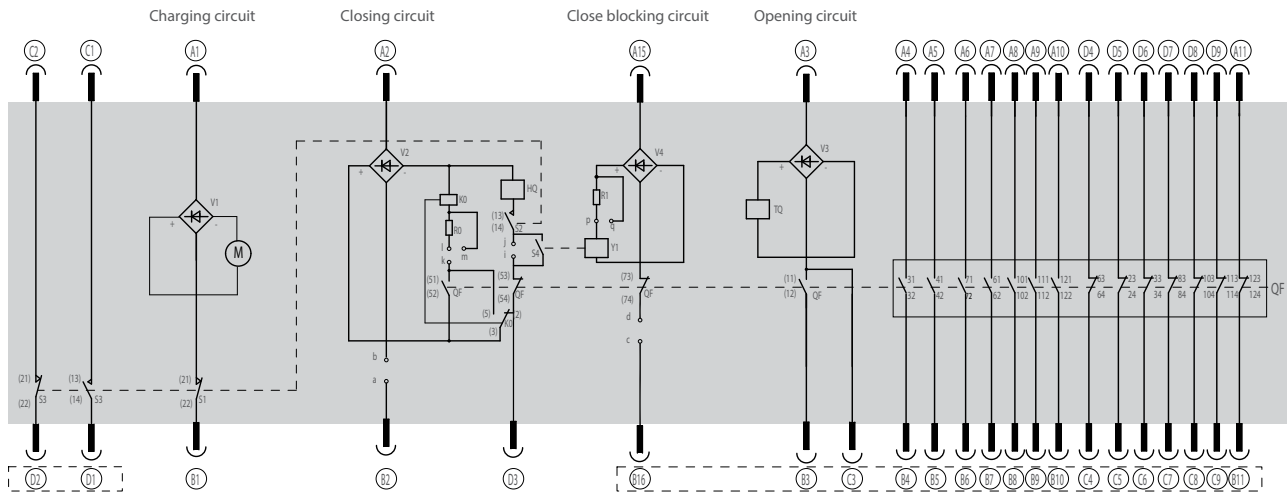

the position of optional components:

Status of jumper wire	Jumper wire	Configuration						
		a-b	c-d	a-f	a-g	b-c	i-j	l-k
with anti-pumping relay	with closing block function	✓	✓	/	/	/	/	✓
	without closing block function	/	/	/	/	✓	✓	✓
without anti-pumping relay	with closing block function	✓	✓	/	/	/	/	/
	without closing block function	/	/	/	/	✓	✓	/

Selection of operation:

Operation power	Jumper wire	
	p-q	m-l
AC/DC 220V	/	/
AC/DC 110V	✓	✓

Remark: "/" means open; "✓" means connection

Instruction:

1. The status of breaker in the drawings is on the opening position and not charged
2. When using DC as operation power, make sure the polarity is consistent in the dot line area, connect the motor as the diagram.

QF: Auxiliary switch	HQ: Closing release	Y1: Closing block magnet (optional)
M: Charging motor	TQ: Opening release	V1~V4: Rectifier
S4: Auxiliary switch for block magnet	R0~R1: Resistance	K0: Anti-pumping relay (optional)
S1~S3: Microswitch of motor	A~M: terminal of jumper	





**USA:** Westinghouse  
20 Stanwix Street | Pittsburgh | PA | 15222

**Poland :** Westinghouse LV MV Product sp. z o.o.  
Warsaw, Rondo ONZ 1, 12 floor, 00-124 Warsaw, Poland

**Malaysia :** Westinghouse Lv Mv Product Sdn. Bhd.  
Seberang Perai Selatan 14110 Simpang Ampat  
Pulau Penang, Malaysia

[WWW.westinghouselvmv.com](http://WWW.westinghouselvmv.com)  
Email: [info@westinghouselvmv.com](mailto:info@westinghouselvmv.com)